



**SPORTSMAN'S
GUIDE™**

IMPORT CARTON PACKAGING & MARKING REQUIREMENTS

**SPORTSMAN'S GUIDE
(SG)**

**THIS DOCUMENT EXPLAINS SG'S PACKAGING & CARTON MARKING REQUIREMENTS
FOR DIRECT IMPORT ORDERS.**

TABLE OF CONTENTS

CARTON PACKAGING	3
RE-MAILER PACKAGING.....	3
HARDWARE PACKAGING	4
INDIVIDUAL BRANDED PACKAGING	4
POLY-BAGS & VINYL BAGS	4
CARTONS.....	6
FOOTWEAR CARTON FORMAT	8
MASTER CARTONS	10
RE-MAILABLE MASTER CARTONS	10
PERFORATED MASTER CARTONS	11
HARDLINES	11
FOOTWEAR	12
APPAREL	12
SEALING THE CARTONS.....	13
CAUTION HEAVY MASTER ICON MARKING REQUIREMENT	16
MASTER CARTON MARKINGS.....	17
SINGLE UNIT MASTER CARTON MARKING.....	18
MULTI PIECE MASTER CARTON MARKING	19
SINGLE ITEMS SHIPPING IN MULTIPLE CARTONS	20
CONTAINER LOADING REQUIREMENTS	22
CALIFORNIA PROPOSITION 65.....	23
UPC LABELING	25
LABEL SIZE REQUIREMENTS	25
LABEL PLACEMENT	26
PENALTIES.....	26
CALIFORNIA AIR RESOURCES BOARD (CARB)	27
CARB ATCM LABEL REQUIREMENTS.....	27

CARTON PACKAGING

One SKU per carton: Pack one style, color and size (SKU) per carton only unless this item has been specified as an assortment.

The casepack shipped must match the casepack listed on the quote sheet presented to the Buyer.

If a single SKU does not completely fill a carton, you may fill the master carton with mixed styles and sizes but this must be approved by the Import Specialist. The mixed master carton must be clearly marked on one long vertical side and one short vertical end in bold print “**MIXED SIZES/COLORS**” so that is easily legible for our receiving department. The mixed carton must be clearly itemized on the packing slip.

Penalties: If master carton is not properly marked mixed sizes or colors we may need to audit entire shipment at the vendor’s expense. This will be at a rate of \$40 per hour per person. Please note, audit may occur at time of receipt or at a later date depending on time the discrepancy is found.

RE-MAILER PACKAGING

The Sportsman’s Guide, requires that many items be packaged in remailer cartons that have passed an ISTA-1A package transit test performed by an independent, certified lab (depending on the item, we may require an ISTA-3A test). Questions regarding this requirement should be directed to the Import Specialist or Buyer that provided you with this document.

The Sportsman’s Guide expects all suppliers to pack orders appropriately to prevent crushing or damage. Product damaged due to insufficient packaging may result in a chargeback.

HARDWARE PACKAGING

The hardware must be in a box or a bag. The box/bag must be secured to either the product or attached somehow to the inside of the carton.

Penalties: Failure to secure the hardware may result in a chargeback depending on if we need to use additional labor/materials to ensure the hardware does not fall out of the package during the distribution process.

INDIVIDUAL BRANDED PACKAGING

POLY-BAGS & VINYL BAGS

The Sportsman's Guide requires some private label branded items (all apparel, and some footwear, domestics & hardlines items) to be packaged in a polybag or vinyl bag printed with one of our **SG Private Label** logos. Unless specified otherwise by the Buyer or Import Specialist, the logo should be printed in black and cover a minimum of 20% of one broad side of the bag. Also, the below WARNING must be printed on the back of each and every bag. The text and image must be in capital letters and in black text on a clear bag. The warning and country of origin must cover a minimum of 20% of the surface area on the side of the bag opposite the logo with Country of Origin included below.

- SG Private Label Logo placement- centered 1/3 down from top of the front of the bag
- Country of Origin placement- 3 cm below the warning
- For UPC barcode format reference pages 25-26 of manual

FRONT VIEW



BACK VIEW

*****ATTENTION!!!!*****
*****WARNING!!!!*****
THIS BAG IS NOT A TOY.
KEEP THIS BAG AWAY FROM CHILDREN
KEEP THIS BAG AWAY FROM PETS
SERIOUS INJURY CAN RESULT
DO NOT PLACE ON HEAD
CHOKING HAZARD
MADE IN CHINA

FRONT VIEW



BACK VIEW

*****ATTENTION!!!!*****
*****WARNING!!!!*****
THIS BAG IS NOT A TOY.
KEEP THIS BAG AWAY FROM CHILDREN
KEEP THIS BAG AWAY FROM PETS
SERIOUS INJURY CAN RESULT
DO NOT PLACE ON HEAD
CHOKING HAZARD
MADE IN CHINA

FRONT VIEW



BACK VIEW

*****ATTENTION!!!!*****
*****WARNING!!!!*****
THIS BAG IS NOT A TOY.
KEEP THIS BAG AWAY FROM CHILDREN
KEEP THIS BAG AWAY FROM PETS
SERIOUS INJURY CAN RESULT
DO NOT PLACE ON HEAD
CHOKING HAZARD
MADE IN CHINA

CARTONS

The Sportsman's Guide requires some private label items to have either the **SG Private Label** logo printed on the individual product package or remailer carton (image must be printed on the salable carton – no brand logo is needed on multiple piece master cartons). If specific instructions have not been provided by the Buyer or Import Specialist, the appropriate logo should be reproduced in black, and cover a minimum of 20% of the surface area of the top or long side panel of the carton.



**GUIDE
GEAR**



CASTLECREEK
The Way You Live



HUNTRITE



BOLDERTON

On some smaller items, like flashlights, the **Guide Gear** logo may need to be rendered too small on the salable carton. In these situations, we may accept the text only version **Guide Gear** logo, or the non-tagline version of the **Castlecreek** logo as shown below. Direction for use of either of these logos **MUST** come from the Buyer or Import Specialist.

**GUIDE
GEAR**



BOLDERTON

High resolution versions of our logos, suitable for print reproduction are available from the Import Specialist or Buyer. Under no circumstances are low resolution images to be used. Reproduction or use of any version of our logos, not specifically provided and authorized by us is forbidden. All branded packaging elements **MUST** be pre-approved by the Import Specialist or Buyer prior to use. Failure to use approved branded packaging will result in a chargeback to cover the costs of appropriately re-packaging product.

FOOTWEAR CARTON FORMAT

Send for Buyer Approval - Below is example of carton only

- SG Private Label may be used based on the branding of item
- The footwear box must be in craft brown
- Pick hole is required for all footwear carton packaging

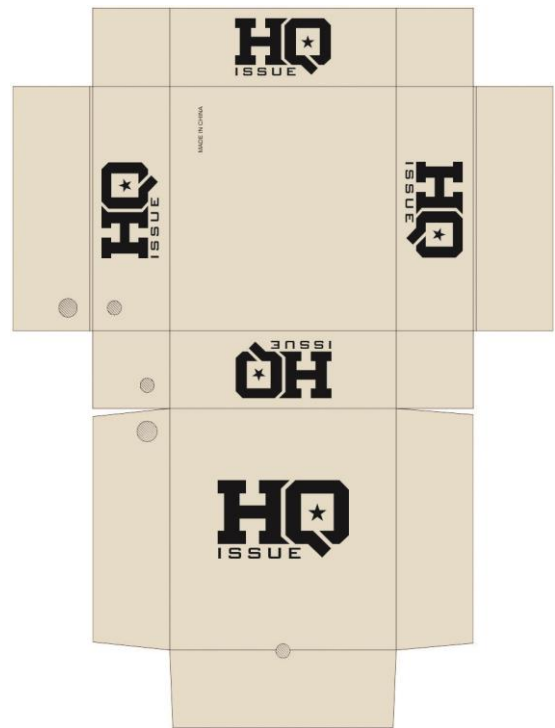
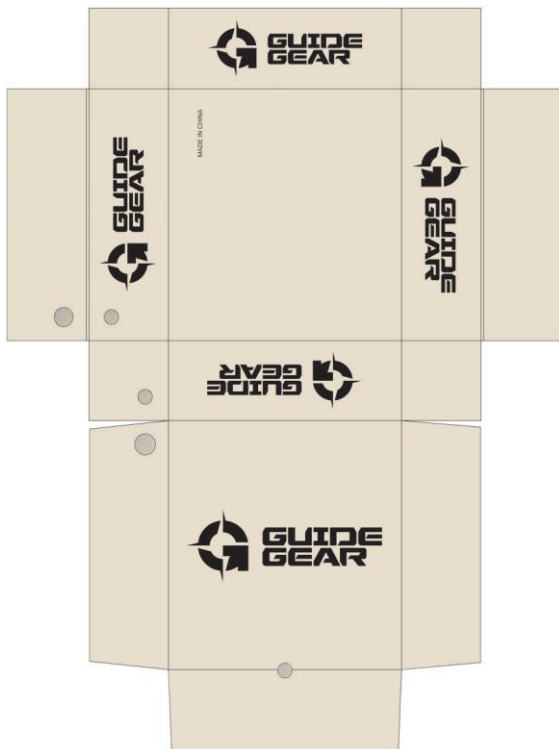

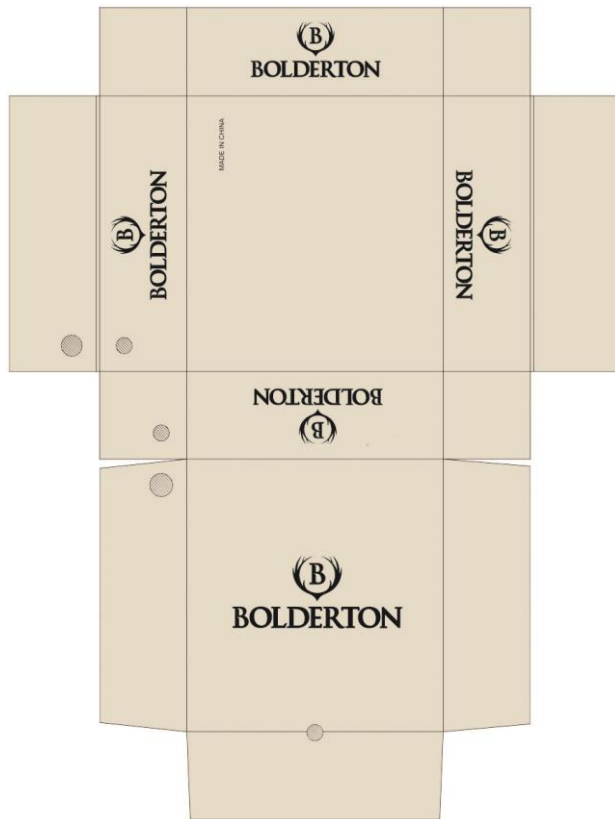
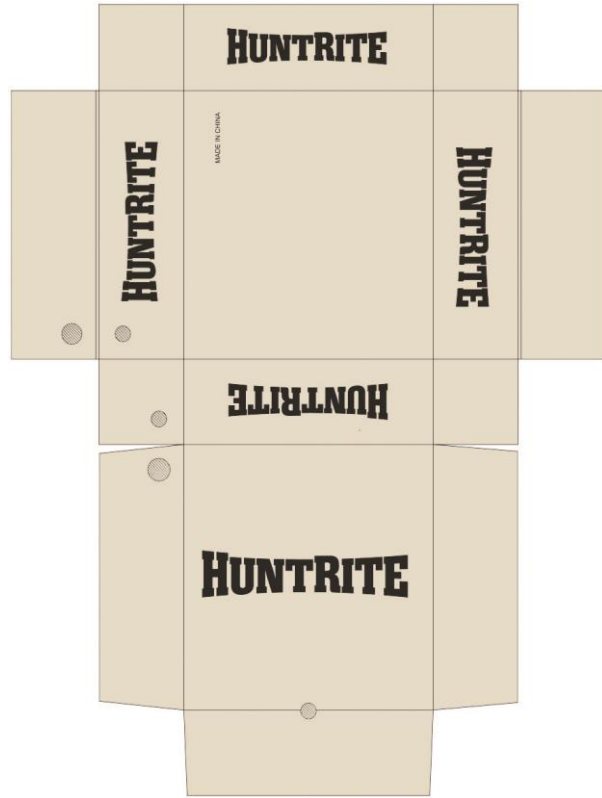

MASTER CARTONS

RE-MAILABLE MASTER CARTONS

When there is only one piece per master carton, the master carton must be re-mailable and is considered the shippable unit. The following burst strength and/or edge crush test (ECT), requirements will apply to one-piece master, remailer cartons. You must check the appropriate section of the Hardlines Import Supplier Manual to see if an exception to the below requirements has been specified for your product category.

Carton Weight (LB)	Bursting Strength or ECT of carton must be at least:	Corrugate Type
0-40.0	275 Burst or 44 ECT	Single-wall (3ply)
41-60	275 Burst or 48 ECT	Single-wall (3ply)
61-90	350 Burst or 51 ECT	Double-wall (5 ply)
91-150	500 Burst or 71 ECT	Double or Triple Wall (3ply or 4 ply)

Single-wall (3 Ply) Corrugate

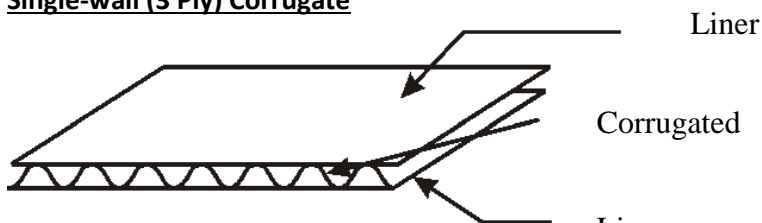

Double-wall (5 Ply) Corrugate

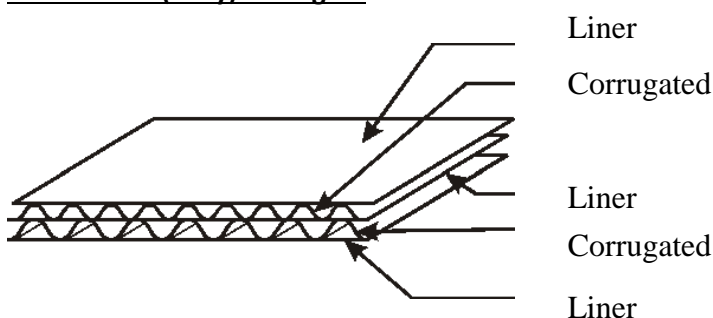

- Cartons for all products weighing 70 lbs or more must have stapled fold over ends.
- The maximum weight for a re-mailable master carton is 150 pounds. If the weight exceeds 150 lbs, please contact the Buyer/Import Specialist.
- The maximum dimensions for a re-mailable master carton, per UPS restrictions, are 165 inches (length + girth). If the carton dimensions exceed 165 inches, please contact the Buyer/Import Specialist.

PERFORATED MASTER CARTONS

If the master carton contains multiple units of the same item, the carton is required to be perforated on the stenciled long side. **On the top line of the carton markings on the perforated panel, it must state "PERFORATED PANEL."** Please see page 14, 15 & 19 for reference.

The vendor can perforate the cartons using multiple options. Below are some recommendations. Please work with your corrugate supplier to find the most effective method.

- Purchase pre die-cut perforated cartons from your corrugate supplier.
- Perforate cartons after purchased using a die-cut rule.
- Use Adalis Open Sesame Tape (for apparel only) 1" down entire top of the carton. See www.adaliscorp.com

Failure to perforate cartons per the below instructions or the failure to include "PERFORATED PANEL" text in the carton markings will result in a chargeback. The Sportsman's Guide will issue a chargeback of \$.25 per carton unless the non-compliance was pre-approved by the buyer as part of the purchase agreement.

The carton perforation specification differs based on the product type; Hardlines, Footwear, Apparel, & Leather Apparel.

HARDLINES

Maximum Carton Dimension: 42" x 24" x 30"

Maximum Carton Weight: 60 pounds

Minimum Carton Dimension: 9" x 6" x 2"

Minimum Carton Weight: none

Please refer to the below instructions when reviewing the following Hardlines Perforation Specification on page 14.

- All perforations must be ¼" x ¼".
- The corrugate board weight minimum for perforated cartons is 44 ect C Natural RG.
- If possible, all products must be positioned in the box to have the UPC label facing the perforated side.
- All four sides on the panel shown on the diagram must be perforated, so it can be removed completely.
- The diagram shown displays the maximum carton size for hardlines. If and when you are using a different size carton, please make sure to maintain the same ratio of the perforated panel to the overall carton size.

FOOTWEAR

Maximum Carton Dimension: 24" x 16" x 16"

Maximum Carton Weight: 60 pounds

No Minimums. If product is unable to fit into these dimensions due to the size of the footwear, please inform the respective Buyer/Import Specialist for approval.

Please refer to the below instructions while reviewing the Footwear Perforation Specification on page 14.

- All footwear must either be in a Guide Gear printed box or in a Guide Gear printed polybag. The Buyer decides the inner packaging for each style of footwear. For all footwear inner carton packaging there must be a pick hole. Please reference pages 8/9.
- All perforations must be ¼" x ¼".
- The corrugate board weight minimum for perforated cartons is 44 ect C Natural RG.
- If possible, all products must be positioned in the box to have the UPC label facing the perforated side.
- All four sides on the panel shown on the diagram must be perforated, so it can be removed completely.
- The diagram shown displays the maximum carton size for footwear. If and when you are using a different size carton, please make sure to maintain the same ratio of the perforated panel to the overall carton size.

APPAREL

Maximum Carton Dimension: 24" x 16" x 16"

Maximum Carton Weight: 60 pounds

Minimum Carton Dimensions: 12" x 12" x 12"

Minimum Carton weight: none

Please refer to the below instructions while reviewing the Apparel Perforation Specification on page 15.

- All shirts/jackets should be flat packed in a Guide Gear polybag with no hanger, and all pants should have a bi-fold with no hanger.
- All perforations must be ¼" x ¼".
- The corrugate board weight minimum for perforated cartons is 44 ect C Natural RG.
- All sides of the panel shown on the diagram must be completely perforated, so it can be removed.
- The diagram shown displays the maximum carton size for apparel. If and when you are using a different size carton, please make sure to maintain the same ratio of the perforated panel to the overall carton size.

SEALING THE CARTONS

All cartons must be taped, glued, or stapled, and no tape must cover any of the carton markings or perforations. Bands should not be used unless the carton weight or dimensions exceed the Sportsman's Guide maximum dimensions and/or weight, and/or is approved by the Buyer/Import Specialist.

Perforated panel – Footwear & Hardlines

CAD Specifications

CUSTOMER NAME: Sportsmans Guide T005741		CUSTOMER PROJECT #:		CUSTOMER PART #:		DATE: 01/19/2017					
PROJECT NAME: 17TC20069 Footwear Perf Panel Bin Box		DESIGNER (OVERALL PROJECT): Terry Gobel (TGOBEL)		FILE DESIGNER:							
PART DESCRIPTION: RSC GJ-IN (C)		STYLE: RSC		BOARD OR MATERIAL: 32 C Kraft		NODE DIMENSIONS (L x W x D): 24 x 16 x 16					
NUMBER PER: 0	ONE OUT SIZE (INCHES):	# OUT LENGTH: 1	# OUT WIDTH: 1	TOTAL # OUT: 1	ROLE TO ROLE BLANK SIZE: 32' 10 x 82	TOTAL ROLE (INCHES): 596.42	BLANK AREA (SQ. FT.): 18.58	PART WEIGHT (LBS): 1.92	SCRAP AREA (%): 1.66	DIE BOARD (#):	SELLING INFO: Machine Glue JOINT DETAILS: Glue In
SPECIAL INSTRUCTIONS 1:											
SPECIAL INSTRUCTIONS 2:											
JOB COUNT: TOTAL SHEET SIZE: 0		DIE BILLING: <input type="checkbox"/> Bill Sep <input type="checkbox"/> Cost Incl		DIE DUE DATE:		SPEC #:		PRICE:		RSC GJ-IN (C)	
										REV: 2	PARENT NUMBER:

View: inside

Corr. Direction: vertical

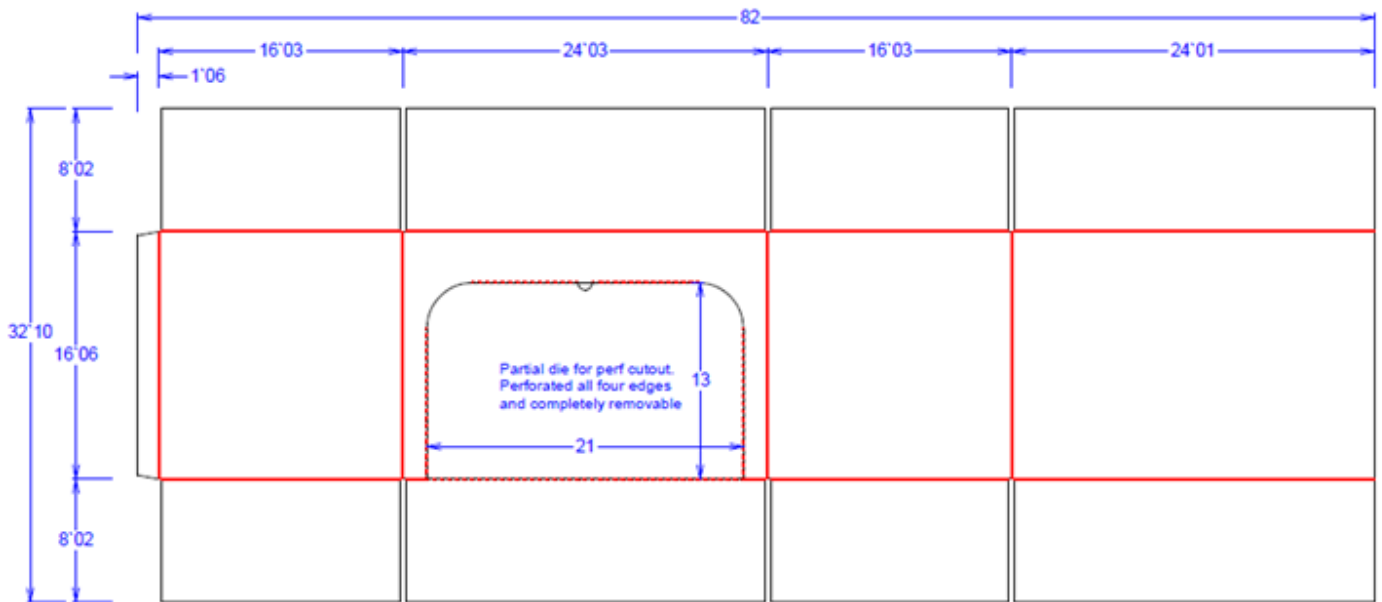

Footwear and Hardlines Perforated Panel

Must be perforated on all four edges, and be completely removable.

Perforated panel – Apparel

CAD Specifications

CUSTOMER NAME Sportsmans Guide T005741		CUSTOMER PROJECT #:		CUSTOMER PART #:		DATE 01/19/2017	
PROJECT NAME 177C20001		PROJECT DESCRIPTION 1/4" Perf Tear away RSC 24 x 16 x 16		DESIGNER (OVERALL PROJECT) Wade Beck (WBECK)		FILE DESIGNER	
PART DESCRIPTION RSC GJ-IN (C)		STYLE RSC		BOARD OR MATERIAL 32 C Kraft		INCH DIMENSIONS (L x W x H) 24 x 16 x 16	
NUMBER PER 0		ONE-DIE SIZE (INCHES) # DYE LENGTH: 1 # DYE WIDTH: 1		TOTAL # DYE: 1		RULE TO RULE BLANK SIZE 32'08 x 82'02	
				TOTAL RULE (INCHES) 602.46		BLANK AREA (SQ FT.) 18.54	
				PART HEIGHT (LBS) 1.91		SCRAP AREA (%) 1.73	
SPECIAL INSTRUCTIONS 1						DIE BOARD #: Machine Glue	
SPECIAL INSTRUCTIONS 2						JOINT DETAILS: Glue In	
JOB COUNT TOTAL SHEET SIZE 0		DIE BILLING <input type="checkbox"/> Bill Sep <input type="checkbox"/> Cost Ind		DIE DUE DATE		SPEC #	
				PRICE		RSC GJ-IN (C)	
						VER 3	
						PARENT NUMBER	

View: inside

Corr. Direction: vertical

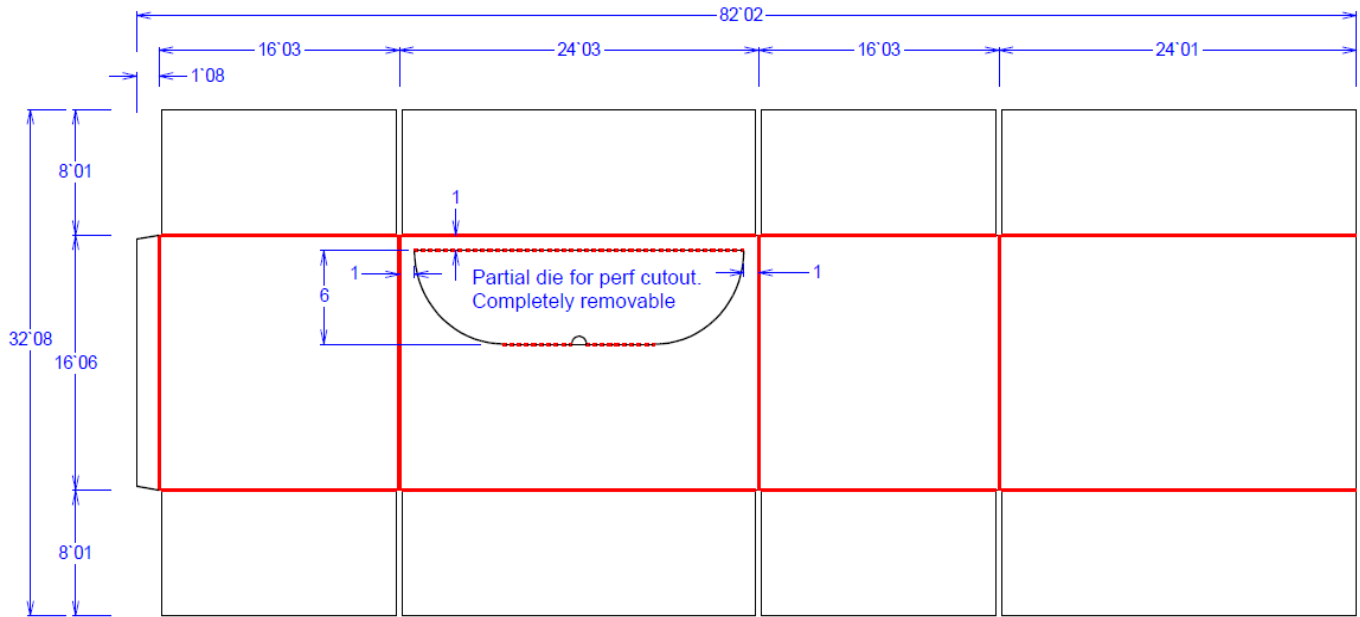

Apparel Perforated Panel
Panel must be perforated all the way around and completely removable

CAUTION HEAVY MASTER ICON MARKING REQUIREMENT

The Caution Heavy Master Icon will be effective on ALL import shipments departing on or after January 1st, 2014. Failure to comply with new marking requirements will result in chargeback penalties.

In order to comply with our safety regulations and to reduce the risk to our customers and associates, we require all vendors to add the CAUTION HEAVY ICON pictured below to unit master cartons weighing over 70 pounds. This image will communicate to our receiving department that two people are required to lift the master carton that is over 70 pounds in order to protect and reduce injury liability.

The team lifting icon shown below is **required to be placed in the bottom right corner of the master shipping carton when applicable**. The icon must appear on at least 2 sides of the box: 1 long end and 1 short end of the box in black print.

If the CAUTION HEAVY ICON is missing from the one piece master carton that is over 70 pounds in weight, the vendor will receive a **\$250.00** chargeback penalty.

- Heavy Icon requirements:
 - Single Unit 1 pc Master Carton
 - Cartons weighing 70 pounds or more
 - Size: minimum size must be 3" x 3"
 - Icon image is available on our import weblink
<https://www.navegate.com/sportsmans/>



ICON: Team Lifting

USE: If box weighs more than 70 pounds (31.75kg), this carton marking icon must be used.

NOTE: This icon will communicate to our receiving department that two people are required to lift the heavy master carton in order to avoid injury within the workplace.

****If you have a similar icon that you would like to use in place of above image, please send to the Import Specialist for approval.****

MASTER CARTON MARKINGS

All required master carton marking information is found on the purchase order. The below elements are required to be listed on every master carton.

Required Elements	Explanation
PERFORATED PANEL	Required if the carton has a perforated panel. Please include this text on the side with perforations.
Consignee Name	Sportsman's Guide
Sportsman's Guide Purchase Order #	(PO#) 10 digits beginning with a 1 Example: PO#1000006131
Sportsman's Guide Item #	(ITM#) 12 digits Example: 111171-000-000
Style #	Vendor Style # / Model # / Stock #
Color and/ or Size	Color and/or Size are required, especially pertaining to soft goods, shoes, and garments.
Case pack or Box 1 of _	Number of selling units in the shipping carton. For single items requiring multiple boxes. This should indicate which box number.
Net Weight / Gross Weight	The actual weight of the master carton.
Made In	Name of Country where the item was manufactured.
Carton Numbers	At Purchase Order Level, Broken by Item# if needed Example: 1 of 426, 2 of 426, etc.

The Markings on the Master cartons must be in the following format:

- All information must be printed in English.
- All information should be stenciled directly on the carton, or should be printed on an adhesive label, which is then applied to the carton.
- Print Specification – The size of the print must be 3/16" (6mm) or larger. All typefaces must be BOLD.
- Print Quality – Information must be printed directly on the carton or a label.

PLACEMENT OF MARKINGS

All required markings should be placed on 1 long vertical side and 1 short vertical end of each carton. If the size of the carton does not allow this, the information may be placed on only one vertical side.

Carton Marking **Examples** Listed on pages 18-21:

SINGLE UNIT MASTER CARTON MARKING

- Carton markings on one long vertical side and one short vertical end
- If master carton is 70lbs or over, please place Caution Heavy Icon at bottom right corner on long vertical side and short vertical end
- UPC barcode sticker placed on upper right hand corner
- Send carton markings for buyer approval
- If applicable, place private label logo on 2 opposite ends of below carton markings (reference pages 6 & 7 for artwork)

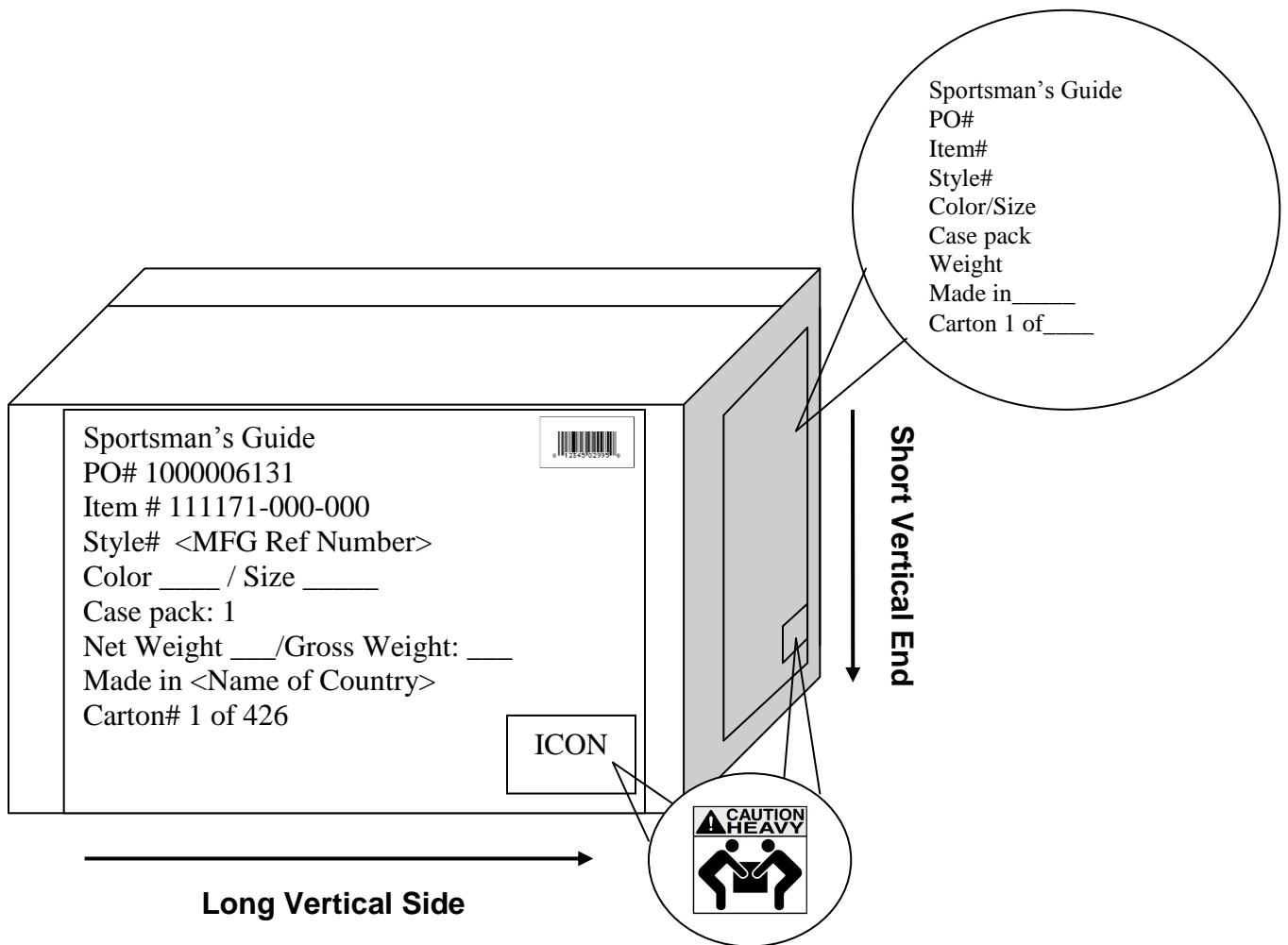

****Caution Heavy Icon: if
70 lbs or more****

MULTI PIECE MASTER CARTON MARKING

Perforated Panel- below is an example of the perforated panel only, reference pages 14/15 for perforated panel instructions specific for your item

- Carton markings on one long vertical side and one short vertical end
- **Perforated Panel:** marking must be on **long vertical** side as pictured below
- If master carton is 70lbs or over, please place Caution Heavy Icon at bottom right corner on long vertical side and short vertical end as pictured below
- Send carton markings for buyer approval.
- **NOTE:** No UPC sticker to be placed on master carton. Please reference page 25 of manual for UPC sticker placement.

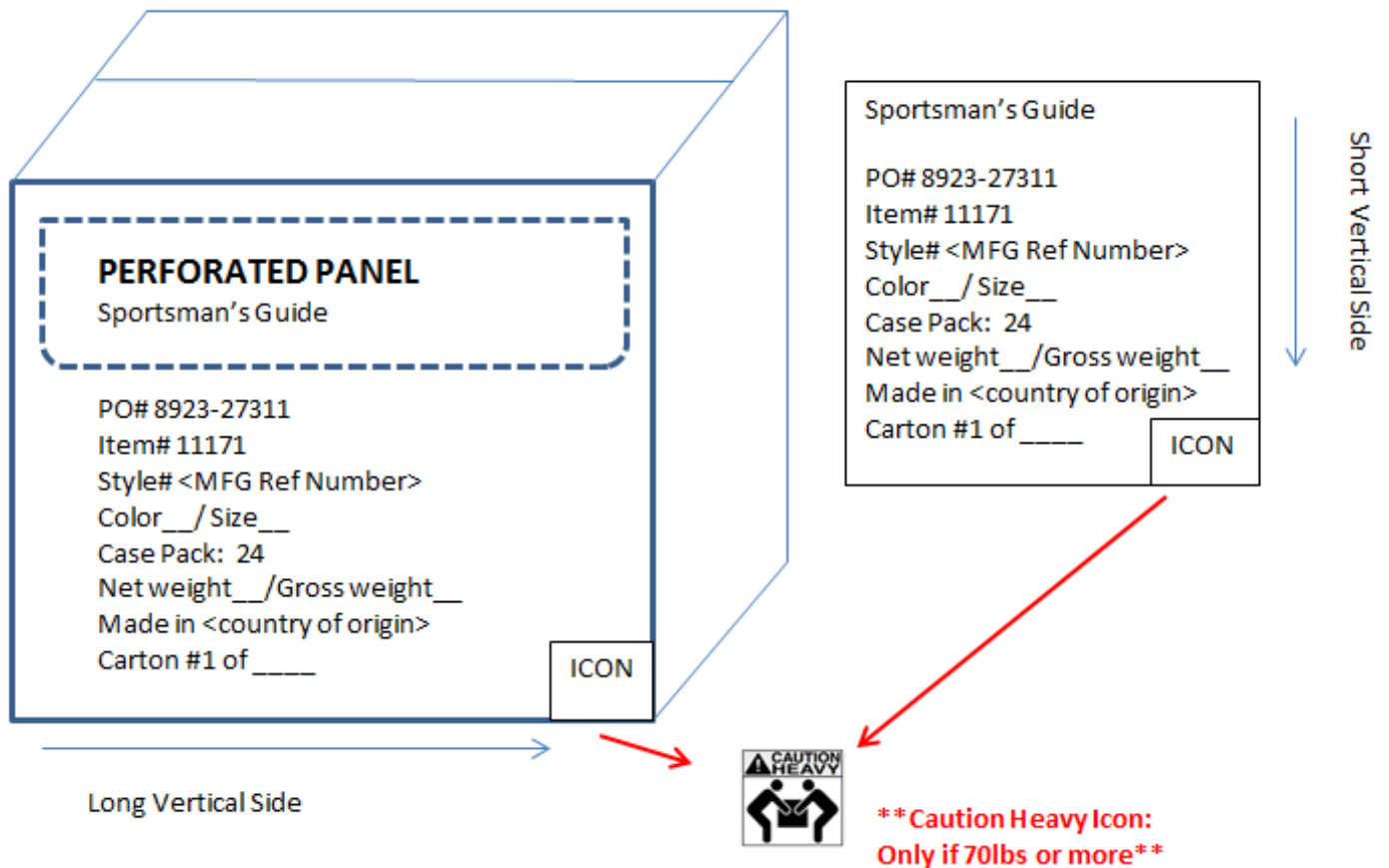

SINGLE ITEMS SHIPPING IN MULTIPLE CARTONS

- Carton markings on one long vertical side and one short vertical end
- If master carton is 70lbs or over, please place Caution Heavy Icon at bottom right corner on long vertical side and short vertical end as pictured below
- UPC barcode sticker
 - Placement: upper right hand corner
 - Use same UPC on BOTH master cartons. Example, Fireplace has 2 cartons place same UPC on both cartons.
- Send carton markings for buyer approval
- If applicable, place private label logo on 2 opposite ends of below carton markings (reference pages 6 & 7 for artwork)

Example: Box 1 of 2

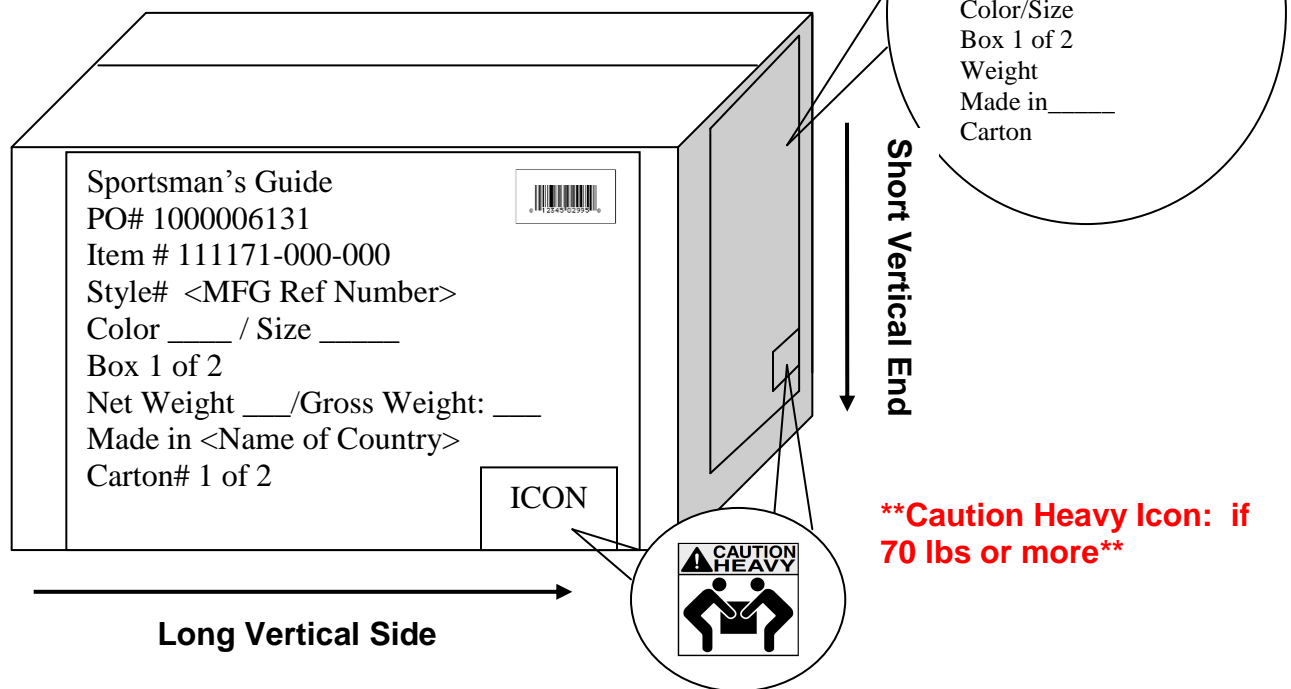

Example: Box 2 of 2

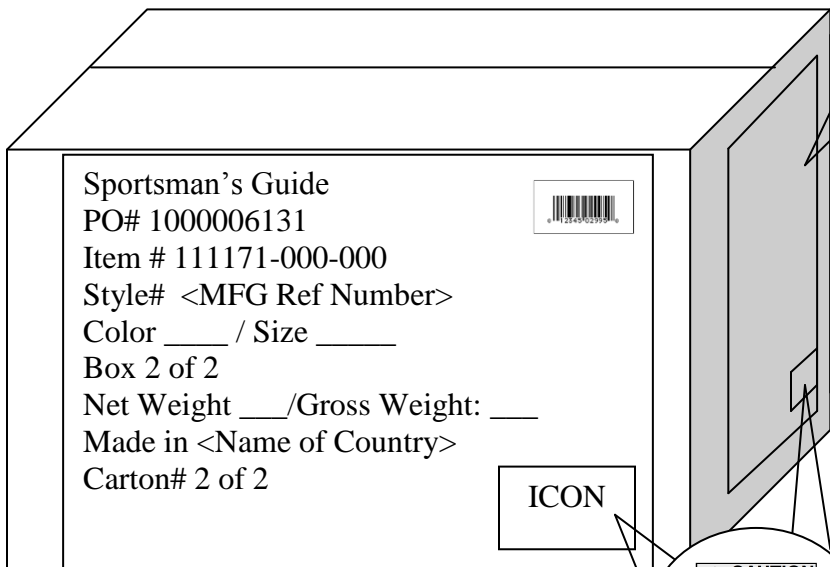

Sportsman's Guide
PO#
Item#
Style#
Color/Size
Box 2 of 2
Weight
Made in ____
Carton

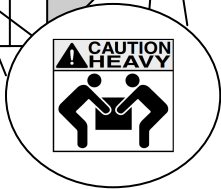

****Caution Heavy Icon: if 70 lbs or more****

CALIFORNIA PROPOSITION 65

California Proposition 65 also known as the Safe Drinking Water and Toxic Enforcement Act enacted in 1986. This law is intended to help Californians make informed decisions about protecting themselves from chemicals known to cause cancer, birth defects, or other reproductive harm.

In late 2016, California adopted new regulations related to the Safe Drinking Water and Toxic Enforcement Act of 1986. The Act and its new regulations update warning requirements for consumer products sold to customers in California that contain certain chemicals. It is expected that all Private Label Brand packaging must comply with the regulations conforming to the new standards.

It is the responsibility of the vendor to comply with all California Proposition 65 requirements, failure to do so shall entitle the Sportsman's Guide to cancel/return the order(s), withhold payment and/or charge back for all damages, losses, penalties, attorney fees and related expenses incurred as a result of any such failure.

For any shipments departing January 1, 2018 or after, Sportsman's Guide will be enforcing the below rules for California Proposition 65.

LABELING: In Lieu of testing we will require a warning label to be placed on your product.

- SG will proceed with the short form California Proposition 65 Warning on all Private Label Product EXCEPT Furniture items.
- If you manufacture an item that is considered household furniture, you must use the new furniture warning label only. Do not use the short form warning label on your furniture product.

PLACEMENT OF WARNING LABEL:

- 1pc master carton for individual product : place the warning under the UPC sticker
- Multiple piece master carton : place the warning on the individual polybag or inner carton under the UPC sticker (must be on the salable carton or packaging)

EXCEPTIONS TO LABELING : DO NOT put a warning label on the below product categories. They must be tested with Intertek and pass California Proposition 65.

- **FOOD PROCESSING**
- **CLOTHING**
- **BEDDING**

SHORT FORM WARNING: USED ON ALL CATEGORIES EXCEPT FOOD PROCESSING, CLOTHING, BEDDING, AND FURNITURE

- The word « WARNING » in all capital letters and bold print.
- The warning symbol, which consists of a black exclamation point in a white or yellow equilateral triangle.
- The entire warning must be in a type size no smaller than the largest type size used for other consumer information on the product. In no case shall the warning appear in a type size smaller than 6-point type.
- Warning logo format as pictured below is posted to our weblink <https://www.navegate.com/sportsmans/>
- You may use the color warning logo or the black and white warning logo.



FURNITURE WARNING : MUST BE USED ON ALL HOUSEHOLD FURNITURE ITEMS

- The word « WARNING » in all capital letters and bold print.
- The warning symbol, which consists of a black exclamation point in a white or yellow equilateral triangle.
- The entire warning must be in a type size no smaller than the largest type size used for other consumer information on the product. In no case shall the warning appear in a type size smaller than 6-point type.
- Warning logo format as pictured below is posted to our weblink <https://www.navegate.com/sportsmans/>
- You may use the color warning logo or the black and white warning logo.

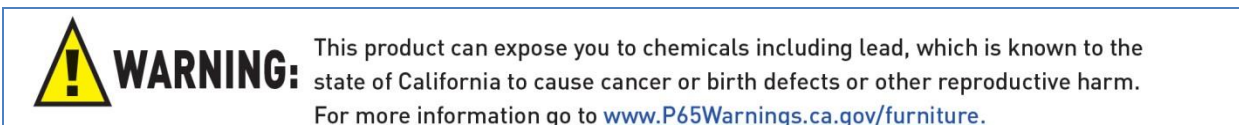

Please contact the Import Specialist if you have any questions or concerns regarding the California Proposition 65 warning label.

****CHARGEBACK**:** Any shipment missing or having an incorrect California Proposition 65 label after January 1, 2018 will result in a \$500.00 chargeback plus \$0.50 per piece to relabel the product.

For additional information re: California Proposition 65, please visit the following sites listed below:

<http://www.oehha.ca.gov/prop65.html>.

<https://www.p65warnings.ca.gov/products/furniture-products>

<https://www.p65warnings.ca.gov/>

UPC LABELING

Each individual piece of product must have a Universal Product Code (UPC), label. This label must include the Sportsman's Guide UPC barcode provide on the purchase order. Each SKU number will be assigned a UPC number at the initial set-up into our system. The Sportsman's Guide 12 digit UPC number will always begin with our 6 digit manufacturer base ID (885344), followed by a 5 digit assigned UPC item number, and end with a final check digit computed from the preceding 11 numbers.

NOTE:

If the manufacturer has already assigned a UPC to an item we wish to order, The Sportsman's Guide may opt to use the existing manufacturer's UPC verses generating one of our own. All deviations from using a UPC generated by The Sportsman's Guide need to be pre-approved by the Buyer prior to a purchase order being issued.

EXAMPLE:



LABEL SIZE REQUIREMENTS

Each label must be a minimum of 3 inches in length and 2 inches in width; it may be larger, but not to exceed 6 inches in length and 4 inches in width. The UPC label should represent a single quantity (1 pc) of that item. If the minimum label size is bigger than the finished packaged size of the product (which would cause the label to fold over the sides or edges), please let the buyer know immediately. Smaller UPC labels may be accepted, but must be pre-approved by the buyer.

LABEL PLACEMENT

The label placement is dependent on the product type, and the label must be placed on each individual salable unit.

- Hardlines – Please place label on the top right hand corner of the long side of each individual unit carton.
 - Hunting Stands, Ladders & Climbing Sticks require labels on BOTH long, vertical sides of each product carton.
- Footwear – Please place the UPC label on the top right hand corner of the short vertical end of the box, or on the top right hand corner of a polybag.
- Apparel & Leather Apparel – Please place the UPC label on the front of the polybag in the **bottom right hand corner**.

The label should be at least ½” away from the bottom edge and top edge of the carton or package, and no closer than ½” from the right carton edge.

APPROVAL PROCESS

For all orders, we will require a sample of all UPC labels to be sent to the Import Specialist for approval of print (text & visibility), label quality, scannability, and adhesiveness.

If the vendor or manufacturer has proved through numerous orders that they can supply quality UPC labels, the buyer or Import Specialist may give them a written approval to waive the sample requirement for future orders.

PENALTIES

If any or all of a shipment comes in without a UPC label or a faulty, non-scannable label, the Sportsman’s Guide will be forced to label/re-label all of the shipment.

If labeling discrepancies occur we may need to audit the whole shipment at the vendor’s expense. This will be at a rate of \$40 per hour per person in addition to \$0.30 per label that must be replaced.

CALIFORNIA AIR RESOURCES BOARD (CARB) AIRBORNE TOXIC CONTROL MEASURE (ATCM) COMPLIANCE

Applies to all products containing wood composite panels

The Sportsman's Guide requires all products containing wood composite materials to be in compliance with CARB ATCM and labeled per the requirements.

CARB ATCM LABEL REQUIREMENTS

All labels must contain the following information:

- Fabricator Name (MUST list the Vendor Name as it is listed on the Purchase Order, NOT The Sportsman's Guide)
- Date the finished goods were produced (month and date at the minimum)
- The Sportsman's Guide purchase order #
- A statement of compliance to denote that the composite wood product or finished good complies with the ATCM. Finished goods made with the NAF/ULEF based resins shall be labeled as such. Statement MUST include the word California or CARB and the section reference "93120". For example:
 - (i) California 93120 Phase 2 compliant for formaldehyde; or
 - (ii) CARB 93120 Phase 2 compliant for formaldehyde - produced with only ULEF-based products.

The labels must be readable and in English.

Placement of the labels MUST be on the product's packaging in the form of a permanent print or stamp in an indiscreet location and in a manner that will withstand transportation. Labels should not replace or cover TSG other required labeling. Please note that the company who appears on the label as the fabricator is assuming responsibility for the compliance of the product with the ATCM.

Example Label Layout:

Fabricator Name: (as it appears on our purchase order - ***Not The Sportsman's Guide***

Production Date of Finished Goods (month & date): _____

TSG PO # _____

A statement of compliance to denote that the composite wood product or finished good complies with the ATCM. Finished goods made with the NAF/ULEF based resins shall be labeled as such. Statement MUST include the word California or CARB and the section reference "93120". For example:

- (i) California 93120 Phase 2 compliant for formaldehyde; or
- (ii) CARB 93120 Phase 2 compliant for formaldehyde - produced with only ULEF-based products.

For more information regarding CARB ATCM, please visit our import procedure webpage, <https://www.navegate.com/sportsmans/>.